

MATERIAL SPECIFICATIONS:

FABRICATED POSTALUMINUM A.S.T.M.

B209, ALLOY 6061-T6.

RAIL & SLEEVES: EXTRUDED ALUMINUM

A.S.T.M. B221, ALLOY 6061-T6.

RAIL HARDWARE: TOGGLE BOLT A.S.T.M.

B165, TYPE TS.

ANCHOR HARDWARE: ANCHOR BOLT,

A.S.T.M. A36, GALVANIZE PER A153.

HEX NUT, A.S.T.M. A563, GALVANIZE

PER A153. FLAT WASHER, A.S.T.M.

A436, GALVANIZE PER A153.

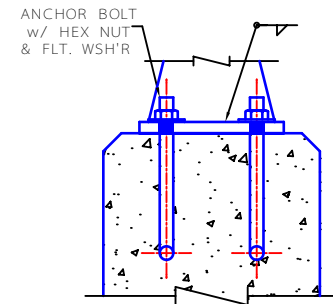
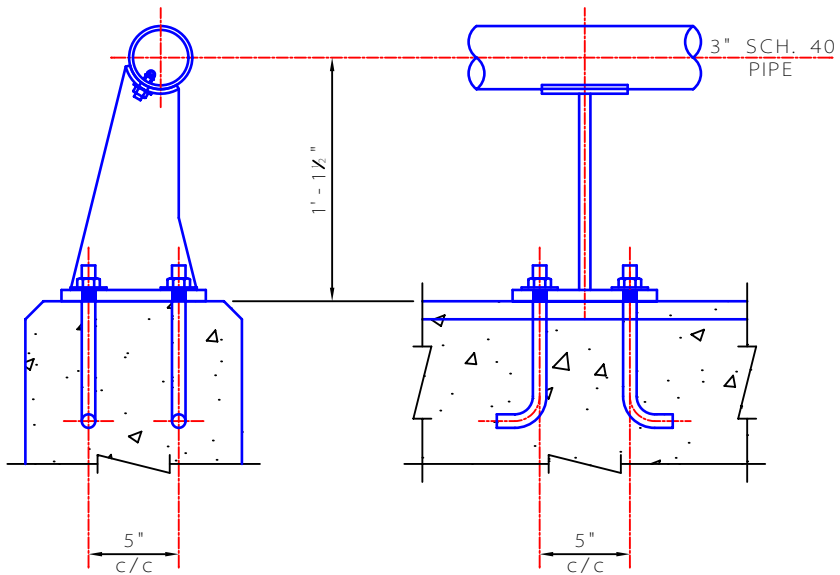

L. B. FOSTER COMPANY
 1016 GREENTREE ROAD
 PITTSBURGH, PA. 15220

BRIDGE RAIL SYSTEM FOR:
 PENNSYLVANIA

STYLE:	FABRICATED
TYPE:	1 - LINE
MATERIAL:	ALUMINUM

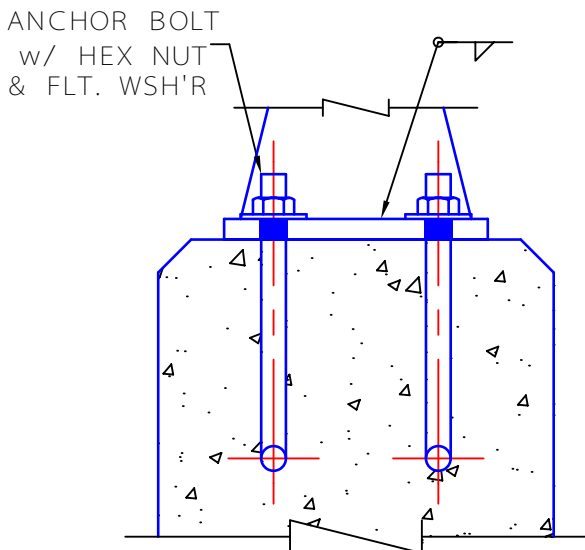
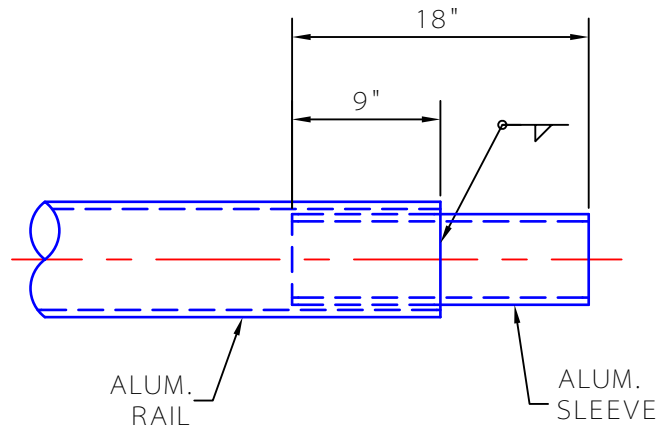
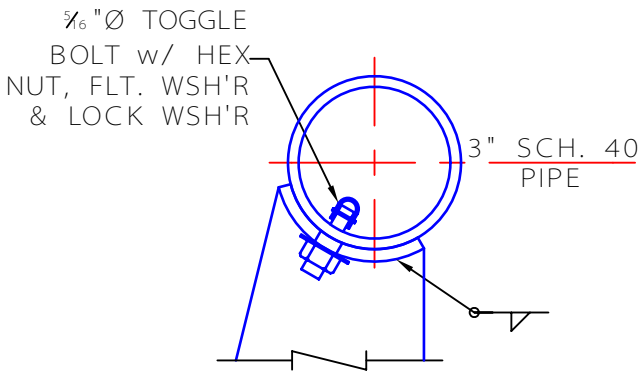
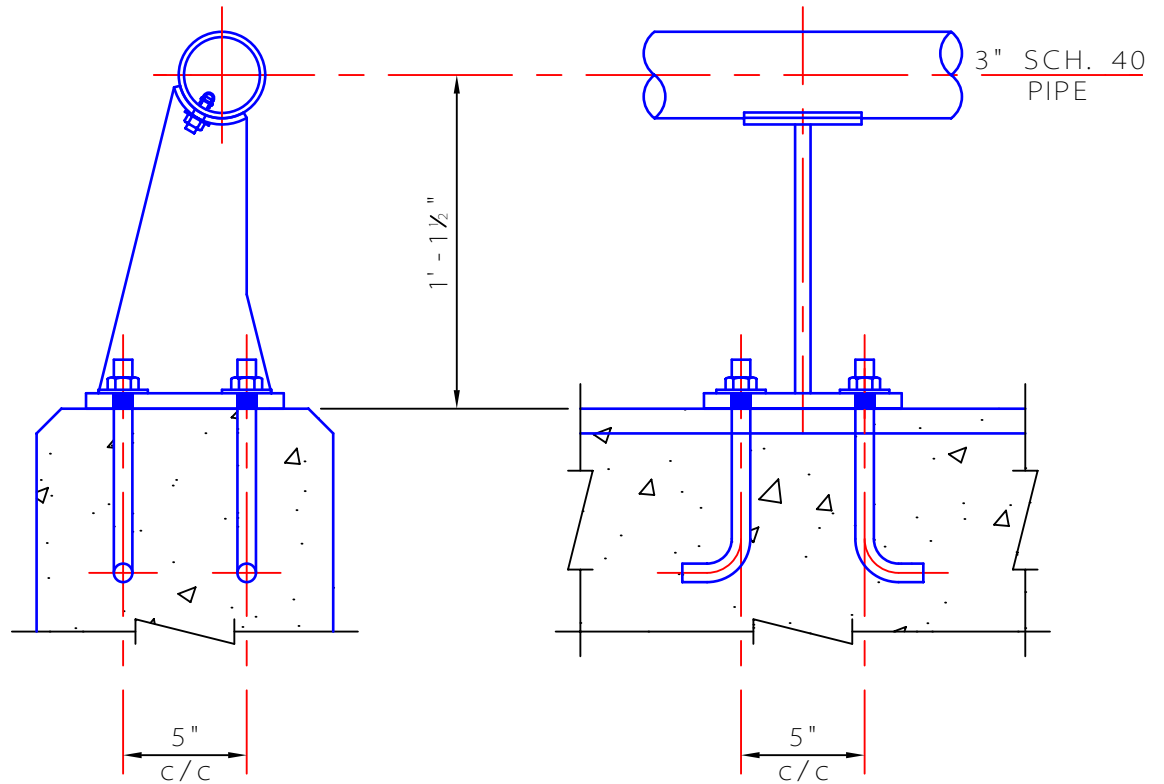

MATERIAL SPECIFICATIONS:

FABRICATED POSTALUMINUM A.S.T.M.

B209, ALLOY 6061-T6.

RAIL & SLEEVES: EXTRUDED ALUMINUM

A.S.T.M. B221, ALLOY 6061-T6.

RAIL HARDWARE: TOGGLE BOLT A.S.T.M.

B165, TYPE TS.

ANCHOR HARDWARE ANCHOR BOLT,

A.S.T.M. A36, GALVANIZE PER A153.

HEX NUT, A.S.T.M. A563, GALVANIZE

PER A153. FLAT WASHER, A.S.T.M.

A436, GALVANIZE PER A153.