

CONCRETE TIE 200S-50

The 200S-50 concrete tie is a high performance, cost effective alternative for mainline applications. The cost to build new track with concrete ties is very competitive with wood tie track, with lower installation cost, improved performance and substantially reduced maintenance costs.

LIFE CYCLE COST SAVINGS

Easier installation, fewer required ties per track mile, greater life expectancy and reduced maintenance equals substantial life cycle cost savings.

PROVEN PERFORMANCE

CXT Concrete Ties has successfully supplied over 14 million concrete ties to the North American market.

SUSTAINABILITY

A track using CXT concrete ties has greater vertical and lateral stiffness. In concert with the consistent, non-shifting gauge, this drastically reduces maintenance for loose rails and fasteners and track related derailments are virtually eliminated.

CXT is the only North American concrete tie producer that is both PCI and ISO 9001:2015 certified.



BENEFITS

» Ease of Installation

Our concrete ties, utilizing a fully captive system with a pre-set gauge, can be installed at rates of up to 1,200 ties per day using CXT's specially designed clamp. Call for rental pricing.

» Greater Efficiency

Approximately 25% fewer concrete ties per track mile are required versus timber or other types of ties.

» Greater Life Expectancy

Concrete ties outlast other types of ties with a design life of 50 years.

» Reduced Maintenance

Stiffer foundation for the entire track system will reduce required lining and surfacing maintenance and provides accurate track gauge.

» Greater Fuel Economy

Less friction and stiffer track structure allow rolling stock to move with less resistance providing less fuel consumption.

» Environmentally Safe

Concrete ties contain no hazardous chemicals that harm the environment.

» Excellent Gauge Holding

Elastic fastening system increases resistance to longitudinal rail movement developed by thermal stress and traffic loads.

» Safety

Limited lateral and longitudinal movement of rail reduces derailments and minimizes derailment damage.

LB Foster[®]
CXT[®] Products

CONCRETE TIE 200S-50

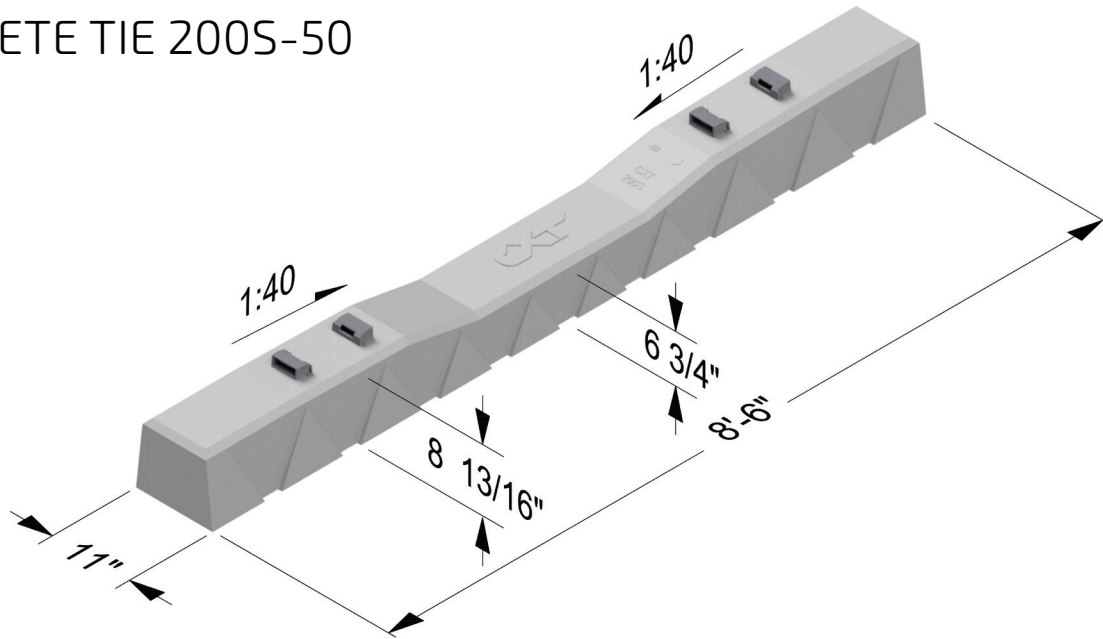

SPECIFICATIONS

Elastic Fastener System:	Safelok III
Design Weight:	700lb
Length:	8' 6"
Flexural Strength:	Railseat positive: 319 in-kips Center negative: 218 in-kips
Tie Spacing:	Meets AREMA structural performance criteria for tie spacing from 24" to 28" on center
Concrete:	7,000 psi minimum 28 day compressive strength with air entrainment
Pad:	7.5mm 3-part pad
Rail Seat Cant:	1:40
Rail Section:	141 lb rail or other 6" base rail sections

The 200S-50 tie is designed for use with Safelok III fully captive fastening system. These components are chosen for their performance, cost and ease of installation.



Efficient installation using hydraulic clamp

LB Foster[®]
CXT[®] Products

2420 N. Pioneer Lane
Spokane, WA 99216
800.790.2292
www.lbfoster.com